



BEST AVAILABLE COPY

(12) UK Patent (19) GB (11) 2 350 137 (13) B

(54) Title of Invention
Hanging liners by pipe expansion

(51) INT CL⁷: E21B 43/10 33/04 33/13 33/14

(21) Application No
0010798.7

(22) Date of filing
04.05.2000

(30) Priority Data

(31) 09315411

(32) 20.05.1999

(33) US

(60) Parent of Application No(s)
0112502.0
under Section 15(4) of the
Patents Act 1977

(43) Application published
22.11.2000

(45) Patent published
08.08.2001

(52) Domestic classification
(Edition S)
E1F FJT FLA

(56) Documents cited
GB2346398 A
GB2326896 A
GB2296023 A
GB2221482 A
GB2079819 A
EPO881354 A
US5667011 A

(58) Field of search

As for published application
2350137 A viz:
UK CL(Edition R) E1F FAC
FAW FJT FKG FLA
INT CL⁷ E21B 17/08 33/04
33/13 33/14 33/16 43/10
Online: EPODOC, JAPIO, WPI
updated as appropriate

(72) Inventor(s)
John L Baugh
Rodney J Bennett
George E Givens

(73) Proprietor(s)
Baker Hughes Incorporated

(Incorporated in USA -
Delaware)

3900 Essex Lane
Suite 1200
P.O. Box 4740
Houston
Texas 77210-4740
United States of America

(74) Agent and/or
Address for Service
Frank B Dehn & Co
179 Queen Victoria Street
London
EC4V 4EL
United Kingdom

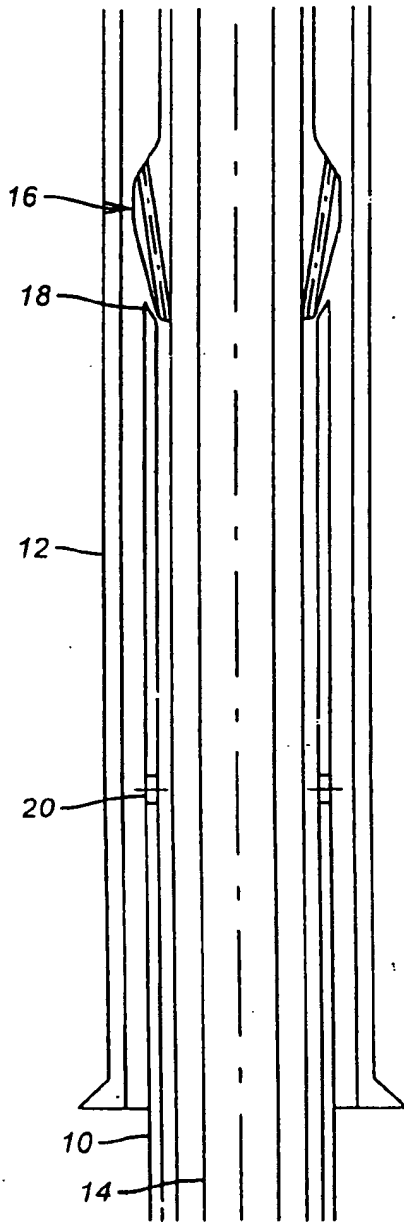

FIG. 1

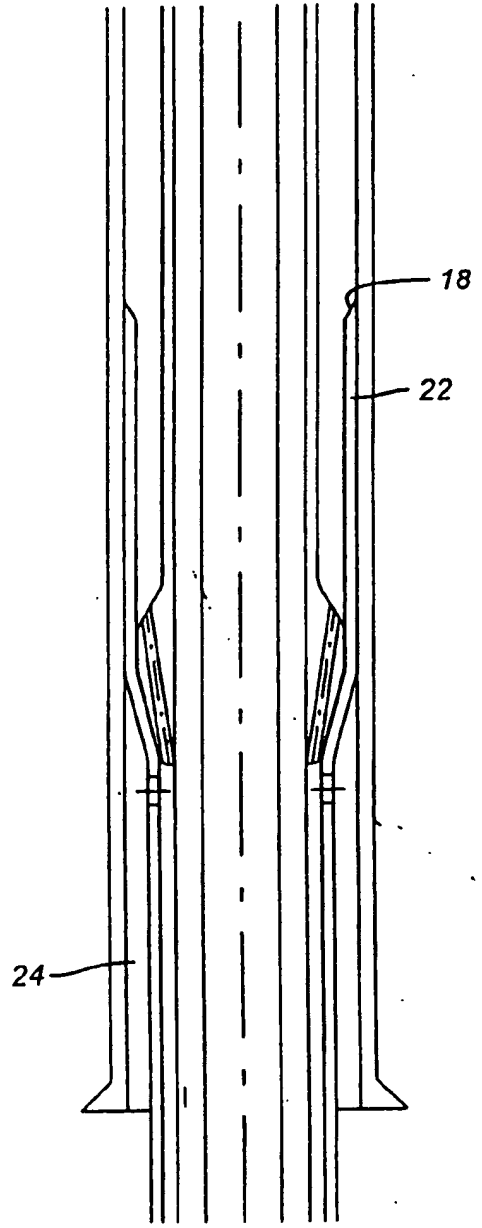

FIG. 2

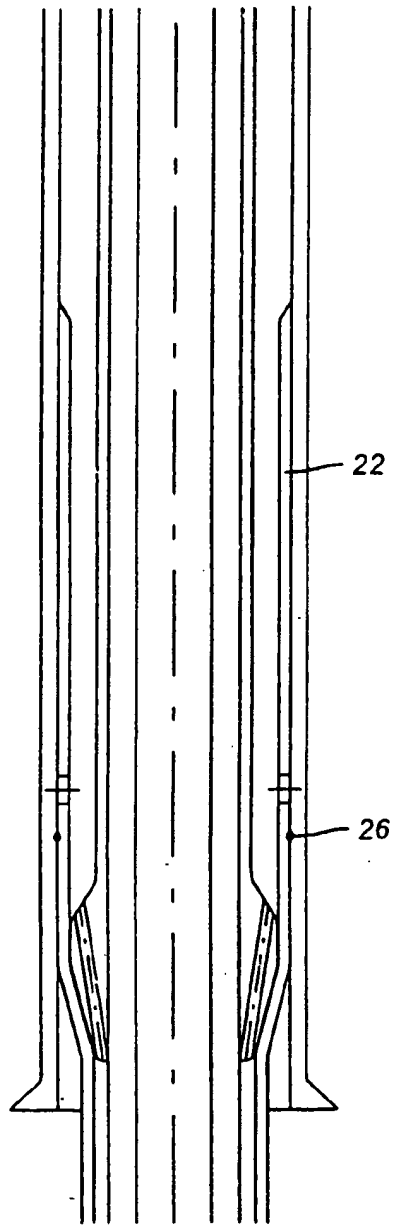

FIG. 3

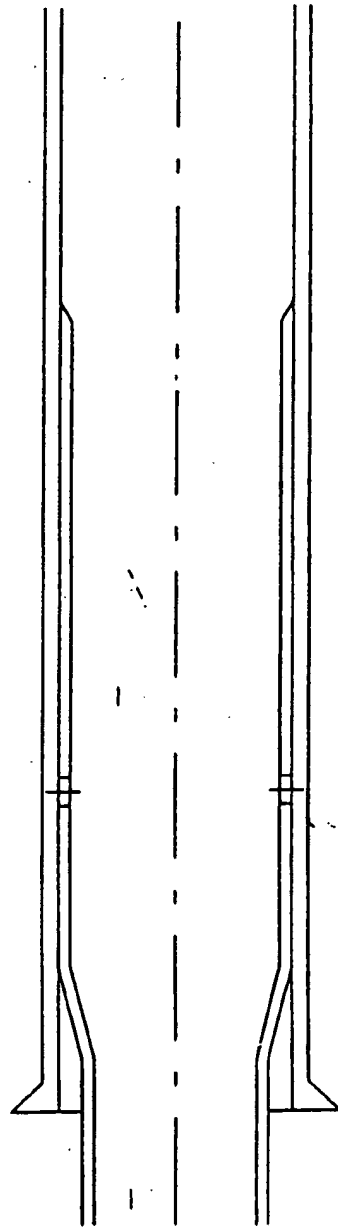

FIG. 4

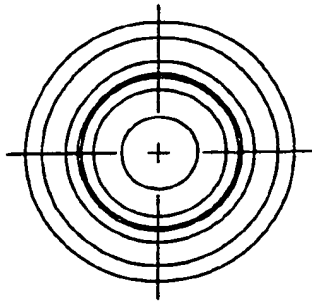

FIG. 6

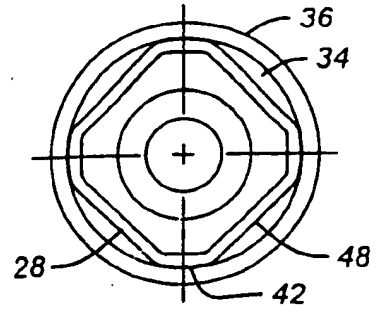

FIG. 8

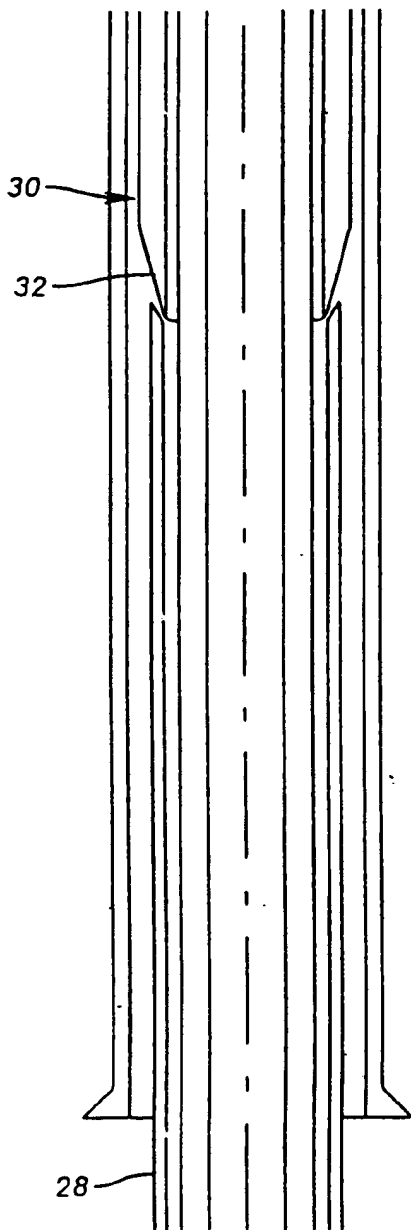

FIG. 5

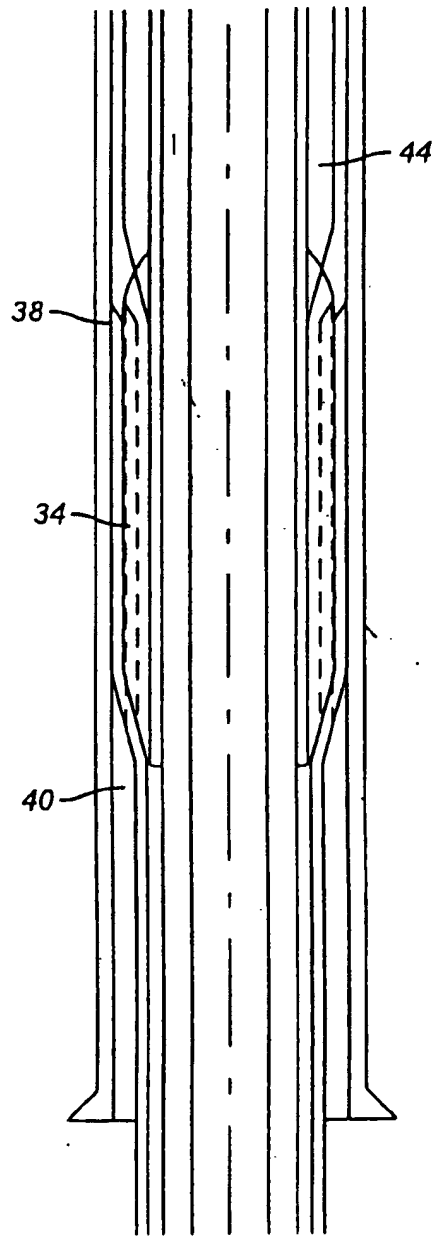

FIG. 7

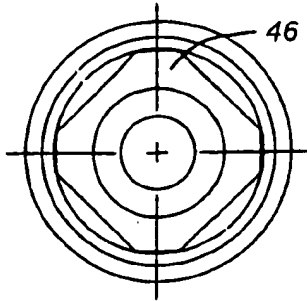

FIG. 10

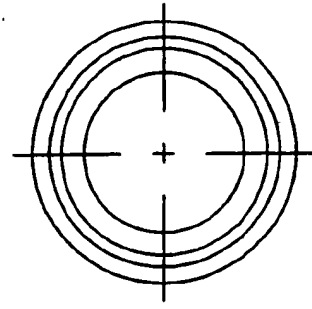

FIG. 11a

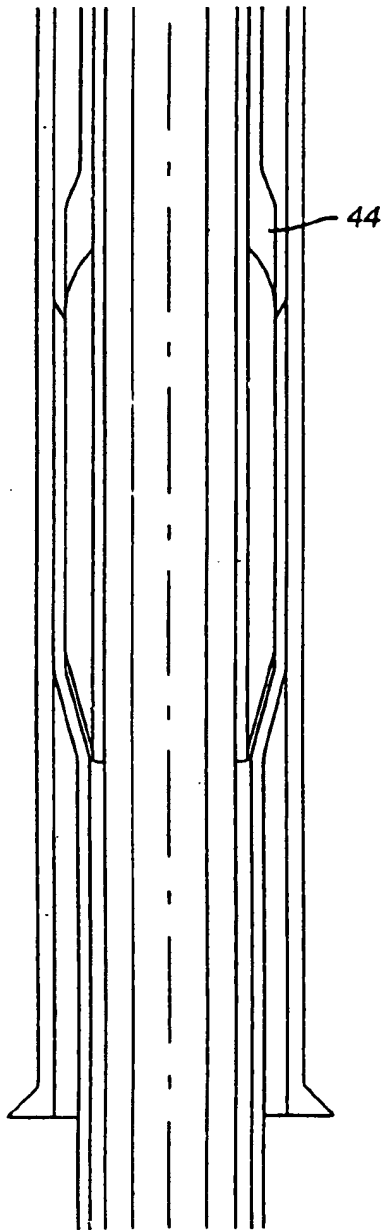

FIG. 9

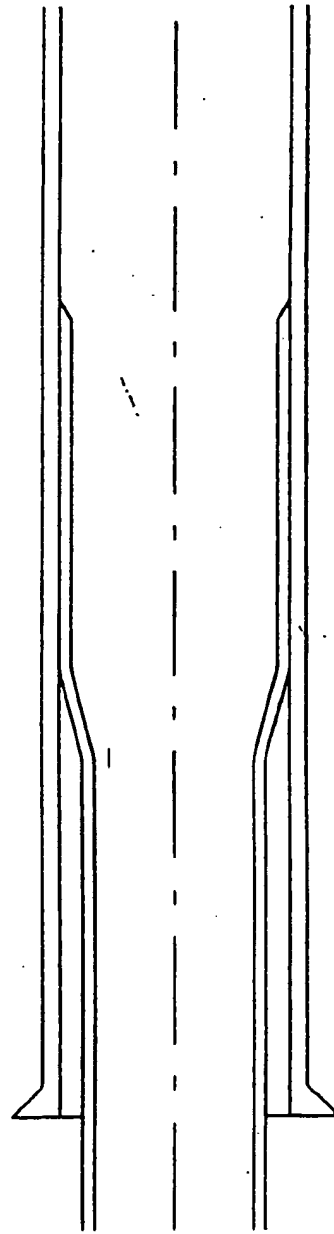

FIG. 10

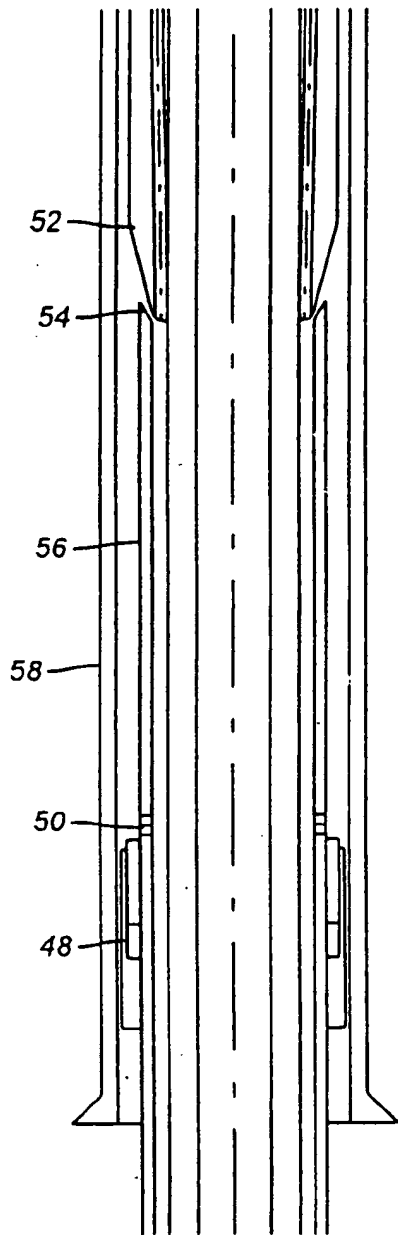

FIG. 12

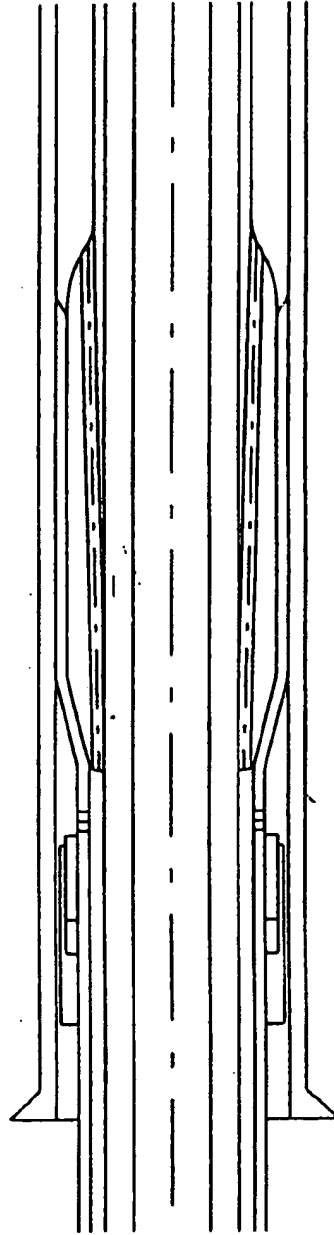

FIG. 13

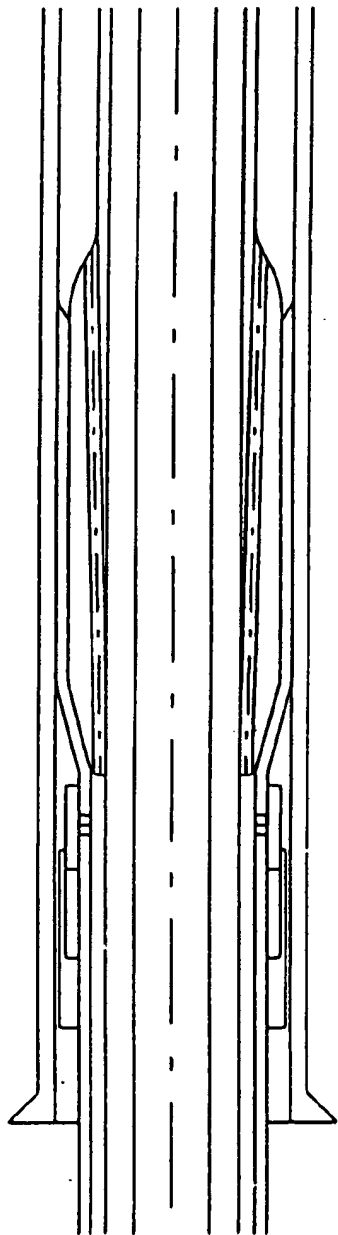

FIG. 14

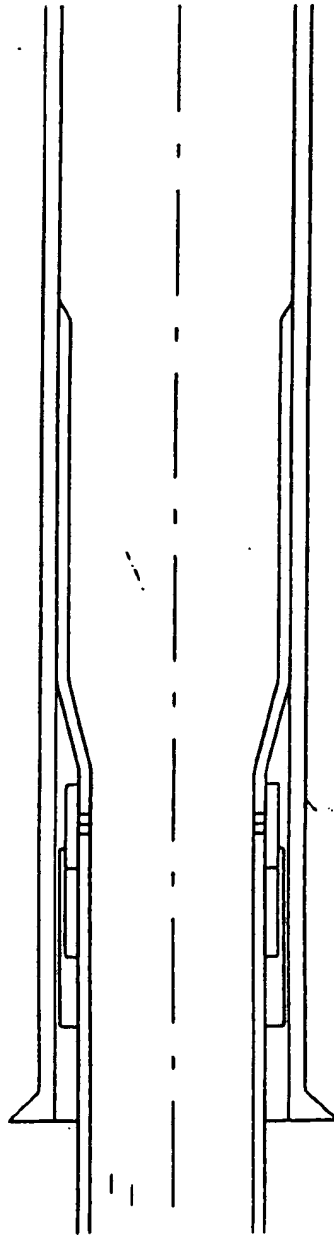

FIG. 15

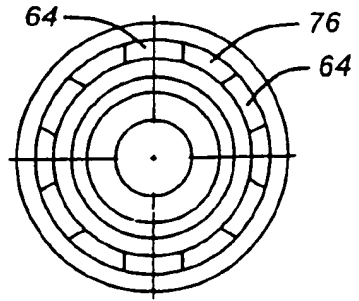

FIG. 17a

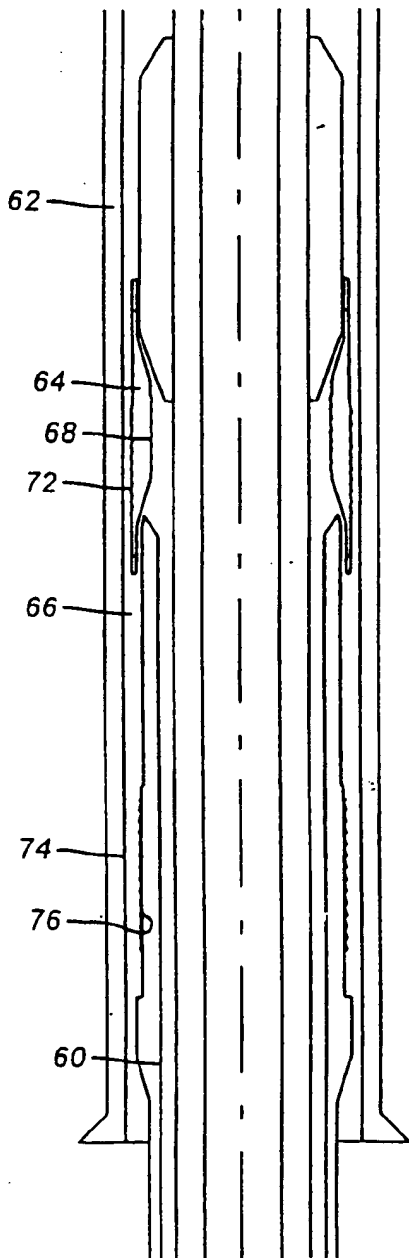

FIG. 16

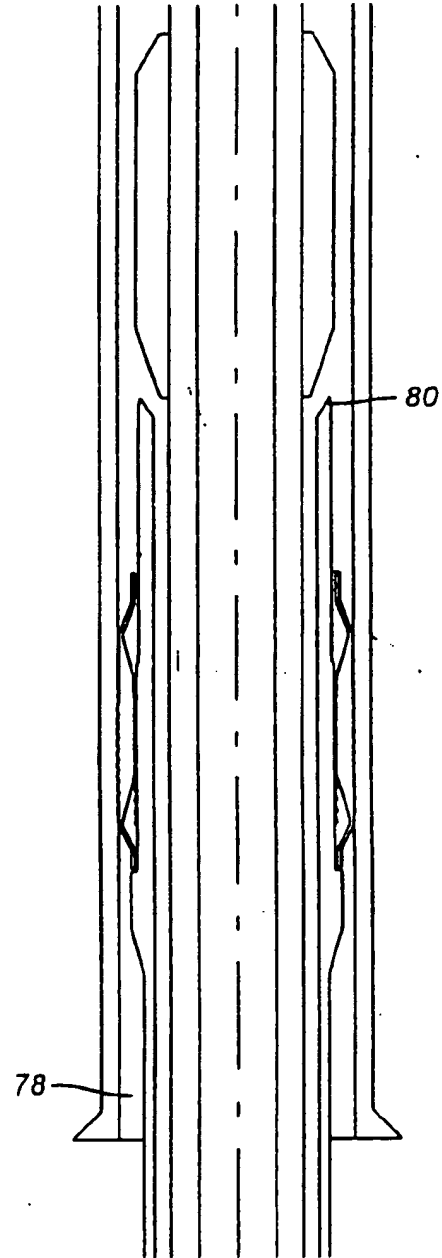

FIG. 17

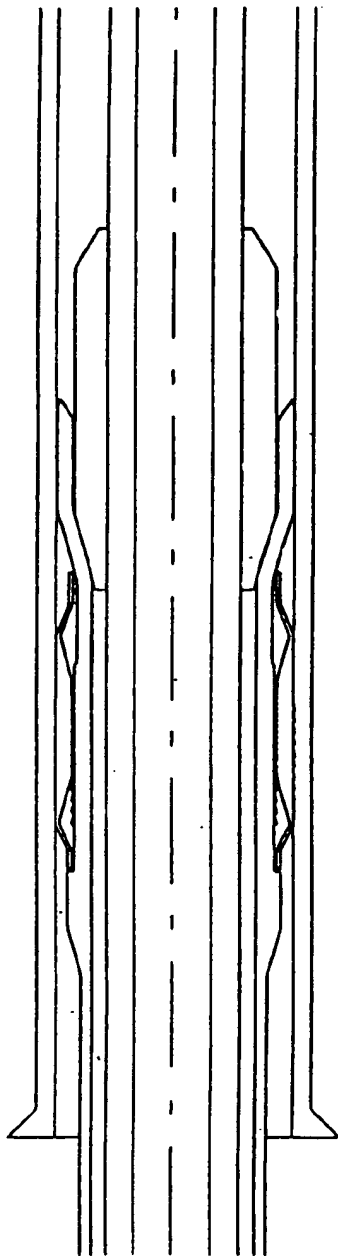

FIG. 18

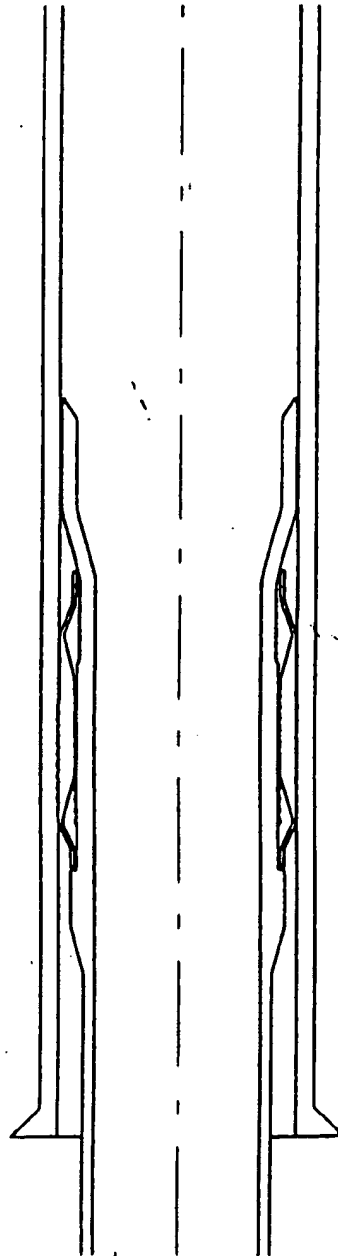

FIG. 19

9/11

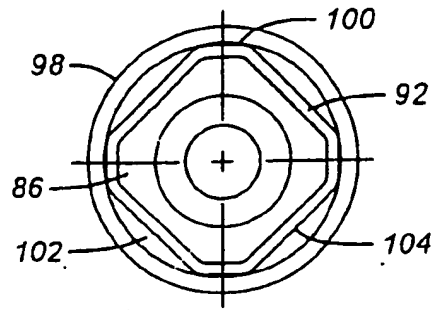

FIG. 22

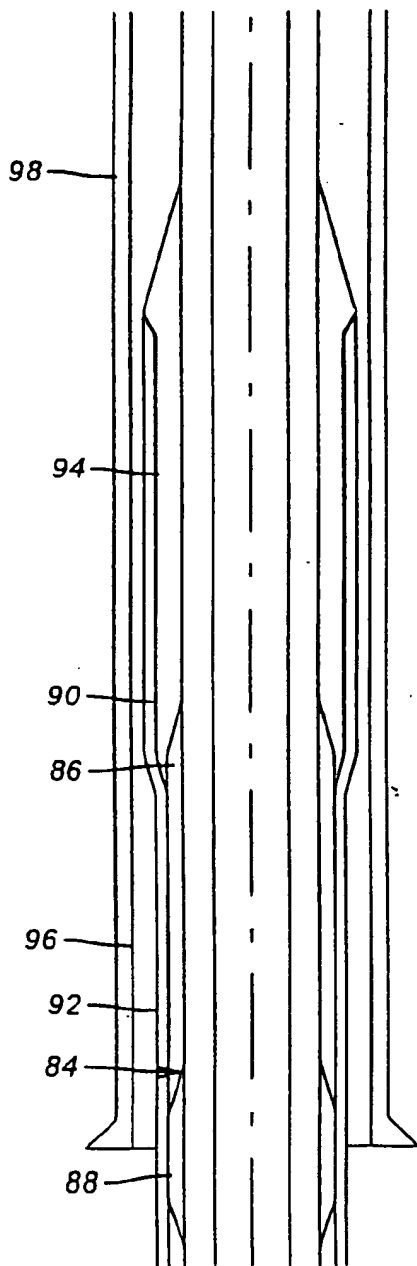

FIG. 20

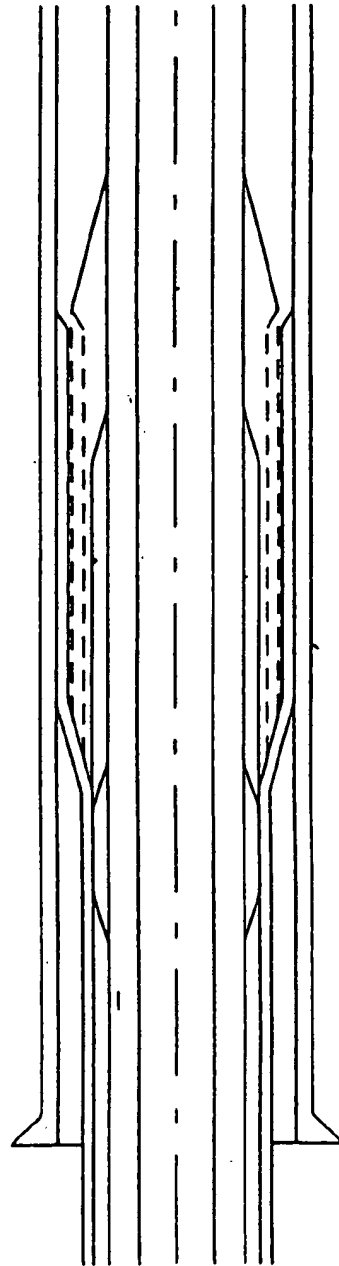

FIG. 21

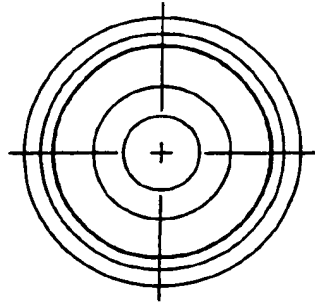

FIG. 24

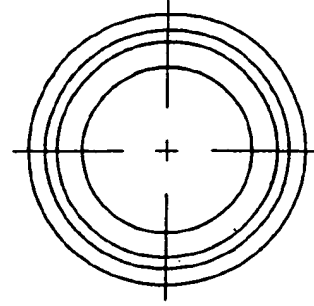

FIG. 26

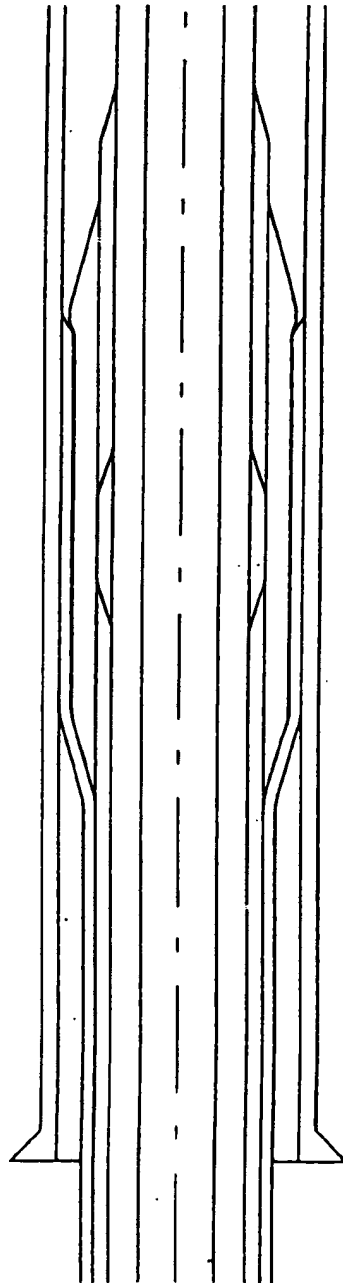

FIG. 23

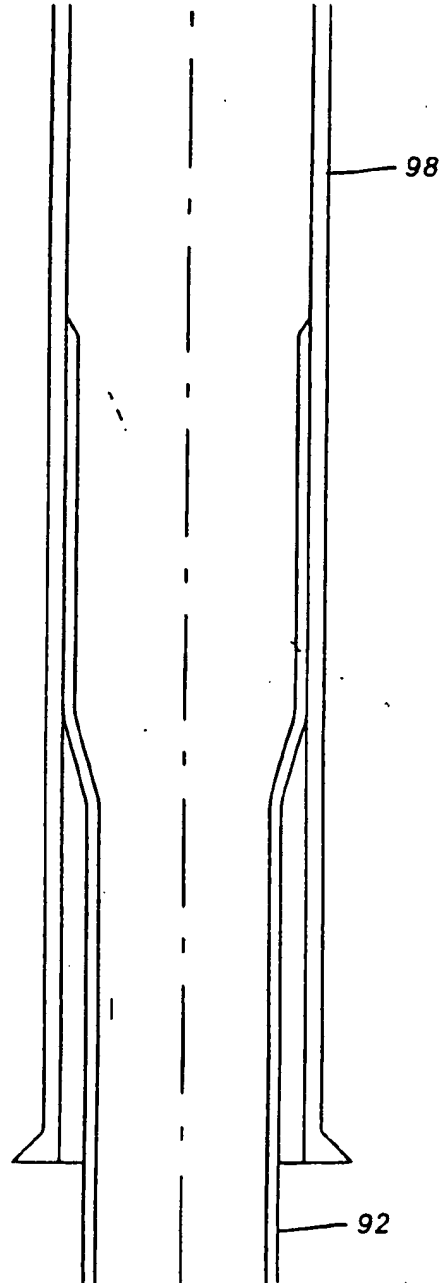

FIG. 25

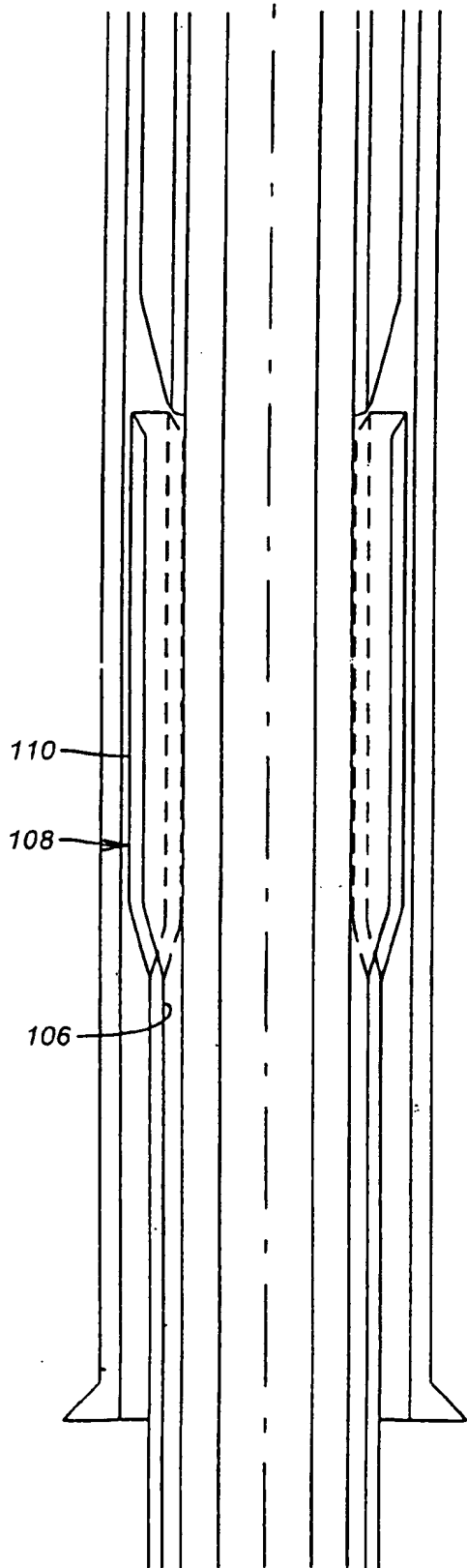

FIG. 27

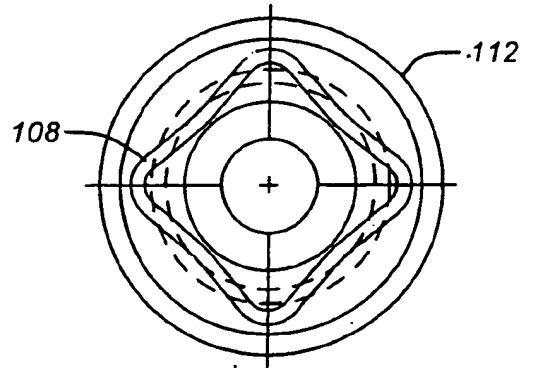

FIG. 28

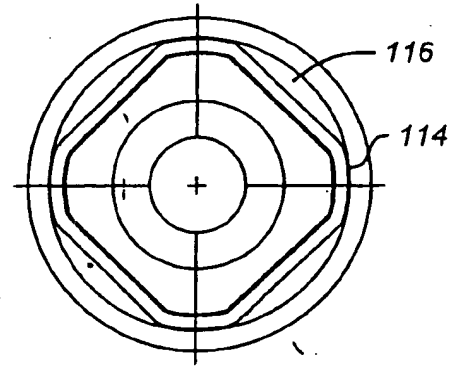

FIG. 29

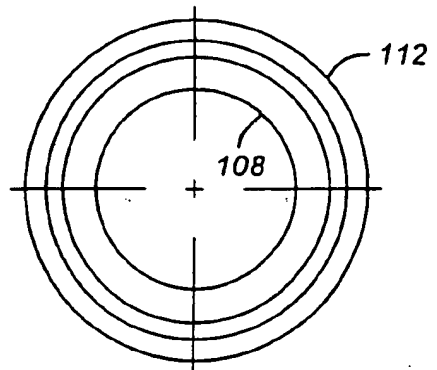

FIG. 30

HANGING LINERS BY PIPE EXPANSION

5

The field of this invention relates to suspending one tubular in another, especially hanging liners which are to be cemented.

10

In completing wellbores, frequently a liner is inserted into casing and suspended from the casing by a liner hanger. Various designs of liner hangers are known and generally involve a gripping mechanism, such as slips, and a sealing mechanism, such as a packer which can be of a variety of designs.

15

The objective is to suspend the liner during a cementing procedure and set the packer for sealing between the liner and the casing. Liner hanger assemblies are expensive and provide some uncertainty as to their operation down-hole.

20

Some of the objects of the preferred embodiment are to accomplish the functions of the known liner hangers by alternative means, thus eliminating the traditionally known liner hanger altogether while accomplishing its functional purposes at the same time in a single trip into the well. Another objective of the preferred embodiment is to provide alternate techniques which can be used to suspend one tubular in another while facilitating a cementing operation

25

and still providing a technique for sealing the tubulars together. Various fishing tools are known which can be used to support a liner being inserted

into a larger tubular. One such device is made by Baker Oil Tools and known as a "Tri-State Type B Casing and Tubing Spear," Product No. 126-09. In addition to known spears which can support a tubing string for lowering into a wellbore, techniques have been developed for expansion of tubulars down-
5 hole. Some of the techniques known in the prior art for expansion of tubulars downhole are illustrated in U.S. Patents 4,976,322; 5,083,608; 5,119,661; 5,348,095; 5,366,012; and 5,667,011.

10 According to a first aspect of the present invention there is provided a method as claimed in claim 1.

According to a second aspect of the present invention there is provided a method as claimed in claim 7.

15 Various embodiments of the present invention together with other arrangements given for illustrative purposes only will now be described, by way of example only, and with reference to the accompanying drawings in which:

Figures 1-4 are a sectional elevation, showing a first embodiment of the method to suspend, cement and seal one tubular to another downhole, using pipe expansion techniques.

20 Figures 5-11a are another embodiment creating longitudinal passages for passage of the cementing material prior to sealing the tubulars together.

Figures 12-15 illustrate yet another embodiment incorporating a sliding sleeve valve for facilitating the cementing step.

25 Figures 16-19 illustrate the use of a grapple technique to suspend the tubular inside a bigger tubular, leaving spaces between the grappling members for passage of cement prior to sealing between the tubulars.

Figures 20-26 illustrate an alternative embodiment involving a sequential flaring of the inner tubular from the bottom up.

Figures 28-30 illustrate an alternative embodiment involving fabrication of the tubular to be inserted to its finished dimension, followed by collapsing it for insertion followed by sequential expansion of it for completion of the operation.

Referring to Figure 1, a tubular 10 is supported in casing 12, using known techniques such as a spear made by Baker Oil Tools, as previously described. That spear or other gripping device is attached to a running string 14. Also located on the running string 14 above the spear is a hydraulic or other type of stroking mechanism which will allow relative movement of a swage assembly 16 which moves in tandem with a portion of the running string 14 when the piston/cylinder combination (not shown) is actuated, bringing the swage 16 down toward the upper end 18 of the tubular 10. As shown in Figure 1 during run-in, the tubular 10 easily fits through the casing 12. The tubular 10 also comprises one or more openings 20 to allow the cement to pass through, as will be explained below. Comparing Figure 2 to Figure 1, the tubular 10 has been expanded radially at its upper end 18 so that a segment 22 is in contact with the casing 12. Segment 22 does not include the openings 20; thus, an annular space 24 exists around the outside of the tubular 10 and inside of the casing 12. While in the position shown in Figure 2, cementing can occur. This procedure involves pumping cement through the tubular 10 down to its lower end where it can come up and around

into the annulus 24 through the openings 20 so that the exterior of the tubular 10 can be fully surrounded with cement up to and including a portion of the casing 12. Before the cement sets, the piston/ cylinder mechanism (not shown) is further actuated so that the swage assembly 16 moves further
5 downwardly, as shown in Figure 3. Segment 22 has now grown in Figure 3 so that it encompasses the openings 20. In essence, segment 22 which is now against the casing 12 also includes the openings 20, thereby sealing them off. The seal can be accomplished by the mere physical expansion of segment 22 against the casing 12. Alternatively, a ring seal 26 can be placed
10 below the openings 20 so as to seal the cemented annulus 24 away from the openings 20. Optionally, the ring seal 26 can be a rounded ring that circumscribes each of the openings 20. Additionally, a secondary ring seal similar to 26 can be placed around the segment 22 above the openings 20. As shown in Figure 3, the assembly is now fully set against the casing 12. The
15 openings 20 are sealed and the tubular 10 is fully supported in the casing 12 by the extended segment 22. Referring to Figure 4, the swage assembly 16, as well as the piston/cylinder assembly (not shown) and the spear which was used to support the tubular 10, are removed with the running string 14 so that what remains is the tubular 10 fully cemented and supported in the casing 12.
20 The entire operation has been accomplished in a single trip. Further completion operations in the wellbore are now possible. Currently, this embodiment is preferred.

Figures 5-12 illustrate an alternative embodiment. Here again, the tubular 28 is supported in a like manner as shown in Figures 1-4, except that
25 the swage assembly 30 has a different configuration. The swage assembly

30 has a lower end 32 which is best seen in cross-section in Figure 8. Lower end 32 has a square or rectangular shape which, when forced against the tubular 28, leaves certain passages 34 between itself and the casing 36. Now referring to Figure 7, it can be seen that when the lower end 32 is brought
5 inside the upper end 38 of the tubular 28, the passages 34 allow communication to annulus 40 so that cementing can take place with the pumped cement going back up the annulus 40 through the passages 34. Referring to Figure 8, it can be seen that the tubular 28 has four locations 42 which are in contact with the casing 36. This longitudinal surface location in contact with the
10 casing 36 provides full support for the tubular 28 during the cementing step. Thus, while the locations 42 press against the inside wall of the casing 36 to support the tubular 28, the cementing procedure can be undertaken in a known manner. At the conclusion of the cementing operation, an upper end 44 of the swage assembly 30 is brought down into the upper end 38 of the
15 tubular 28. The profile of the upper end 44 is seen in Figure 10. It has four locations 46 which protrude outwardly. Each of the locations 46 encounters a mid-point 48 (see Figure 8) of the upper end 38 of the tubular 28. Thus, when the upper end 44 of the swage assembly 30 is brought down into the tubular 28, it reconfigures the shape of the upper end 38 of the tubular 28
20 from the square pattern shown in Figure 8 to the round pattern shown in Figure 12. Figure 11 shows the running assembly and the swage assembly 30 removed, and the well now ready for the balance of the completion operations. The operation has been accomplished in a single trip into the wellbore. Accordingly, the principal difference in the embodiment shown in Figures 1-4
25 and that shown in Figures 5-12 is that the first embodiment employed holes

or openings to facilitate the flow of cement, while the second embodiment provides passages for the cement with a two-step expansion of the upper end 38 of the tubular 28. The first step creates the passages 34 using the lower end 32 of the swage assembly 30. It also secures the tubular 28 to the casing 36 at locations 42. After cementing, the upper end 44 of the swage assembly 30 basically finishes the expansion of the upper end 38 of the tubular 28 into a round shape shown in Figure 12. At that point, the tubular 28 is fully supported in the casing 36. Seals, as previously described, can optionally be placed between the tubular 28 and the casing 36 .

10

Another embodiment is illustrated in Figures 12-15. This embodiment has similarities to the embodiment shown in Figures 1-4. One difference is that there is now a sliding sleeve valve 48 which is shown in the open position exposing openings 50. As shown in Figure 12, a swage assembly 52 fully expands the upper end 54 of the tubular 56 against the casing 58, just short of openings 50. This is seen in Figure 13. At this point, the tubular 56 is fully supported in the casing 58. Since the openings 50 are exposed with the sliding sleeve valve 48, cementing can now take place. At the conclusion of the cementing step, the sliding sleeve valve 48 is actuated in a known manner to close it off, as shown in Figure 14. Optionally, seals can be used between tubular 56 and casing 58. The running assembly, including the swage assembly 52, is then removed from the tubular 56 and the casing 58, as shown in Figure 15. Again, the procedure is accomplished in a single trip. Completion operations can now continue in the wellbore.

15

20

Figures 16-19 illustrate another technique. The initial support of the tubular 60 to the casing 62 is accomplished by forcing a grapple member 64 down into an annular space 66 such that its teeth 68 ratchet down over teeth 70, thus forcing teeth 72, which are on the opposite side of the grappling member 64 from teeth 68, to fully engage the inner wall 74 of the casing 62. This position is shown in Figure 17, where the teeth 68 and 70 have engaged, thus supporting the tubular 60 in the casing 62 by forcing the teeth 72 to dig into the inner wall 74 of the casing 62. The grapple members 64 are elongated structures that are placed in a spaced relationship as shown in Figure 17A. The spaces 76 are shown between the grapple members 64. Thus, passages 76 provide the avenue for cement to come up around annulus 78 toward the upper end 80 of the tubular 60. At the conclusion of the cementing, the swage assembly 82 is brought down into the upper end 80 of the tubular 60 to flare it outwardly into sealing contact with the inside wall 74 of the casing 62, as shown in Figure 18. Again, a seal can be used optionally between the upper end 80 and the casing 62 to seal in addition to the forcing of the upper end 80 against the inner wall 74, shown in Figure 18. The running assembly as well as the swage assembly 82 is shown fully removed in Figure 19 and further downhole completion operations can be concluded. All the steps are accomplished in a single trip.

Figures 20-25 illustrate yet another alternative of the present invention. In this situation, the swage assembly 84 has an upper end 86 and a lower end 88. In the run-in position shown in Figure 20, the upper end 86 is located below a flared out portion 90 of the tubular 92. Located above the upper end 86 is a sleeve 94 which is preferably made of a softer material than the tubular

92, such as aluminum, for example. The outside diameter of the flared out segment 90 is still less than the inside diameter 96 of the casing 98. Ultimately, the flared out portion 90 is to be expanded, as shown in Figure 21, into contact with the inside wall of the casing 98. Since that distance representing that expansion cannot physically be accomplished by the upper end 5 96 because of its placement below the flared out portion 90, the sleeve 94 is employed to transfer the radially expanding force to make initial contact with the inner wall of casing 98. The upper end 86 of the swage assembly 84 has the shape shown in Figure 22 so that several sections 100 of the tubular 92 10 will be forced against the casing 98, leaving longitudinal gaps 102 for passage of cement. In the position shown in Figures 21 and 22, the passages 102 are in position and the sections 100 which have been forced against the casing 98 fully support the tubular 92. At the conclusion of the cementing operation, the lower segment 88 comes into contact with sleeve 94. The shape of lower 15 end 88 is such so as to fully round out the flared out portion 90 by engaging mid-points 104 of the flared out portion 90 (see Figure 22) such that the passages 102 are eliminated as the sleeve 94 and the flared out portion 90 are in tandem pressed in a manner to fully round them, leaving the flared out portion 90 rigidly against the inside wall of the casing 98. This is shown in 20 Figure 23. Figure 25 illustrates the removal of the swage assembly 84 and the tubular 92 fully engaged and cemented to the casing 98 so that further completion operations can take place. Figures 24 and 26 fully illustrate the flared out portion 90 pushed hard against the casing 98. Again, in this embodiment as in all the others, auxiliary sealing devices can be used be-

tween the tubular 92 and the casing 98 and the process is done in a single trip.

Referring now to Figures 27-30, yet another embodiment is illustrated. Again, the similarities in the running in procedure will not be repeated because they are identical to the previously described embodiments. In this situation, the tubular 106 is initially formed with a flared out section 108. The diameter of the outer surface 110 is initially produced to be the finished diameter desired for support of the tubular 106 in a casing 112 (see Figure 28) in which it is to be inserted. However, prior to the insertion into the casing 112 and as shown in Figure 28, the flared out section 108 is corrugated to reduce its outside diameter so that it can run through the inside diameter of the casing 112. The manner of corrugation or other diameter-reducing technique can be any one of a variety of different ways so long as the overall profile is such that it will pass through the casing 112. Using a swage assembly of the type previously described, which is in a shape conforming to the corrugations illustrated in Figure 28 but tapered to a somewhat larger dimension, the shape shown in Figure 29 is attained. The shape in Figure 29 is similar to that in Figure 28 except that the overall dimensions have been increased to the point that there are locations 114 in contact with the casing 112. These longitudinal contacts in several locations, as shown in Figure 29, fully support the tubular 106 in the casing 112 and leave passages 116 for the flow of cement. The swage assembly can be akin to that used in Figures 5-11 in the sense that the corrugated shape now in contact with the casing 112 shown in Figures 29 at locations 114 can be made into a round shape at the conclusion of the cementing operation. Thus, a second portion of the swage assembly as

previously described is used to contact the flared out portion 108 in the areas where it is still bent, defining passages 116, to push those radially outwardly until a perfect full 360° contact is achieved between the flared out section 108 and the casing 112, as shown in Figure 30. This is all done in a single trip.

5 Those skilled in the art can readily appreciate that various embodiments have been disclosed which allow a tubular, such as 10, to be suspended in a running assembly. The running assembly is of a known design and has the capability not only of supporting the tubular for run-in but also to actuate a swage assembly of the type shown, for example, in Figure 1 as item 16. What
10 is common to all these techniques is that the tubular is first made to be supported by the casing due to a physical expansion technique. The cementing takes place next and the cementing passages are then closed off. Since it is important to allow passages for the flow of cement, the apparatus of the present invention, in its various embodiments, provides a technique which
15 allows this to happen with the tubular supported while subsequently closing them off. The technique can work with a swage assembly which is moved downwardly into the top end of the tubular or in another embodiment, such as shown in Figures 20-26, the swage assembly is moved upwardly, out of the top end of the tubular. The creation of passages for the cement, such as 34
20 in Figure 8, 76 in Figure 17A, or 102 in Figure 22, can be accomplished in a variety of ways. The nature of the initial contact used to support the tubular in the casing can vary. Thus, although four locations are illustrated for the initial support contact in Figure 8, a different number of such locations can be used. Different materials can be used to encase the liner up

and into the casing from which it is suspended, including cement, blast furnace slag, or other materials. Known techniques are used for operating the sliding sleeve valve shown in Figure 12-15, which selectively exposes the openings 50. Other types of known valve assemblies are also contemplated. Despite the variations, the technique winds up being a one-trip operation.

5

Those skilled in the art will now appreciate that what has been disclosed is a method which can completely replace known liner hangers and allows for sealing and suspension of tubulars in larger tubulars, with the flexibility of cementing or otherwise encasing the inserted tubular into the larger tubular.

10

The foregoing disclosure and description of the invention are illustrative and explanatory thereof, and various changes in the size, shape and materials, as well as in the details of the illustrated construction, may be made.

Claims

- 5 1. A method of completing a well, comprising:
 running in a tubular string into a cased borehole;
 expanding a portion of said tubular into supporting
 contact with the casing;
 delivering a sealing material through at least one
10 opening in said tubular, with said tubular so supported;
 closing off said opening.
2. The method of claim 1, further comprising:
 expanding said tubular to accomplish said closure
15 after said delivering of said sealing material.
3. The method of claim 2, further comprising:
 using said expanding to close off said opening to
 accomplish a seal between said tubular and said casing.
20
4. The method of claim 3, further comprising:
 providing a seal downhole of said opening as a
 backup seal to any seal formed by said expanding.
- 25 5. The method of claim 1, further comprising:
 pushing said opening against the casing to close
 it.
6. The method of claim 2, further comprising:
30 accomplishing said running in, supporting,
 delivering a sealing material, and closing of said
 opening by expansion, all in a single trip into the
 well.
- 35 7. A method of completing a well, comprising:
 running a tubular string into a cased borehole;
 expanding portions of said tubular string into

contact with the casing for support thereof;

leaving gaps between said tubular string and said casing, with said tubular string supported to said casing;

5 using said gaps for passage of a sealing material; closing said gaps.

8. The method of claim 7, further comprising:

10 providing longitudinal contact between said tubular string and said cased borehole;

defining said gaps as passages between said longitudinal contacts between said tubular string and said cased wellbore.

15 9. The method of claim 8, further comprising:

using a fluted expansion swage to create said longitudinal contact for support of said tubular string; providing offset flutes on said swage, located one above another;

20 using lowermost flutes to create said longitudinal contact;

using offset flutes to subsequently remove said gaps after passage of said sealing material.

25 10. The method of claim 9, further comprising:

offsetting said offset flutes about 90° from said lowermost flutes.

11. The method of claim 7, further comprising:

30 accomplishing said running in, expanding, leaving gaps, passage of said sealing material, and closing said gaps in a single trip into the wellbore.

12. The method of claim 7, further comprising:

35 providing a seal between said tubular string and said cased borehole by said closing of said gaps.

13. The method of claim 1, further comprising:
using full circumferential contact for said
supporting contact.
- 5 14. The method of claim 13, further comprising:
providing a valve with said opening;
operating said valve to close off said opening.
- 10 15. The method of claim 14, further comprising:
providing a sliding sleeve on said tubular string
as said valve.
- 15 16. The method of claim 7, further comprising:
running in with a swage inside said tubular string;
supporting said tubular string while moving said
swage uphole to expand portions of said tubular string
into contact with said cased borehole for support
thereof.
- 20 17. The method of claim 16, further comprising:
locating a force transfer member inside said
tubular string during run-in;
transferring an expansion force from said swage
through said force transfer member to said tubular
25 string for said expansion into said cased borehole for
support thereof.
- 30 18. The method of claim 17, further comprising:
configuring said swage to force said gaps closing
through a force transfer through a sleeve which serves
as said force transfer member.
- 35 19. The method of claim 9, further comprising:
running in with a swage inside said tubular string;
supporting said tubular string while moving said
swage uphole to expand portions of said tubular string
into contact with said cased borehole for support

thereof.

20. The method of claim 19, further comprising:
locating a force transfer member inside said
5 tubular string during run-in;
transferring an expansion force from said swage
through said force transfer member to said tubular
string for said expansion into said cased borehole for
support thereof.
10
21. The method of claim 20, further comprising:
configuring said swage to force said gaps closed
through a force transfer through a sleeve which serves
as said force transfer member.
15
22. The method of claim 7, further comprising:
reducing the diameter of a part of a tubing string
whose original dimension, on said part thereof, was at
least as large as the inside diameter of a cased
20 wellbore, to an outer dimension small enough to fit into
said cased borehole.
23. The method of claim 22, further comprising:
expanding said portion of said tubing string to its
25 said original dimension to close said gaps;
providing said original dimension as larger than
the inside dimension of said cased wellbore;
sealing between said tubing string and said cased
wellbore by forcing said portion of said tubular string
30 into circumferential contact with said cased wellbore.